



## IH IMMERSION HEATER INSTALLATION-OPERATION

### UNIT SELECTION

Selection of the IH heater module should be based on the the following parameters:

- 1) Amount of heat necessary for the system
- 2) Power availability
- 3) Ease of connection with the rest of the system ( i.e. remote panels, chillers, pumps, etc.).

Select a heater module that has as many stages as there are chillers. An example of a standard selection would be as follows:

CHILLERS:	2) A5C Five ton units	Total amperage: 50 amps
REMOTE PANEL:	AQCWPH-02C	
HEATER MODULE:	IH-2401-122 12 kw, 2 stage	Total amperage: 51 amps

In this example there are two chillers and two stages of heat.

It is also possible to have a mismatch between the number of chiller units and the number of stages. An example of this is as follows:

CHILLERS:	3) A4D Four ton units	Total amperage: 39 amps
REMOTE PANEL:	AQCWPH-03C	
HEATER MODULE:	IH-2403-152 15 kw, 2 stage	Total amperage: 36 amps

In this example there are three chillers and two stages of heat.

It is usually desirable, when selecting the IH heater module, to select a unit that does not exceed the total amperage draw of the chiller units. The two previous examples illustrate this.

### UNIT MOUNTING

The IH Series immersion heater tank is designed to be installed in many different positions. Depending upon the amount of space available it may be necessary to mount the unit in a non-standard position. The heater module comes from the factory with the inlet and outlet connections labelled for the standard, upright mounting position. These labels can be moved to alternate positions based upon other approved mounting positions described below.

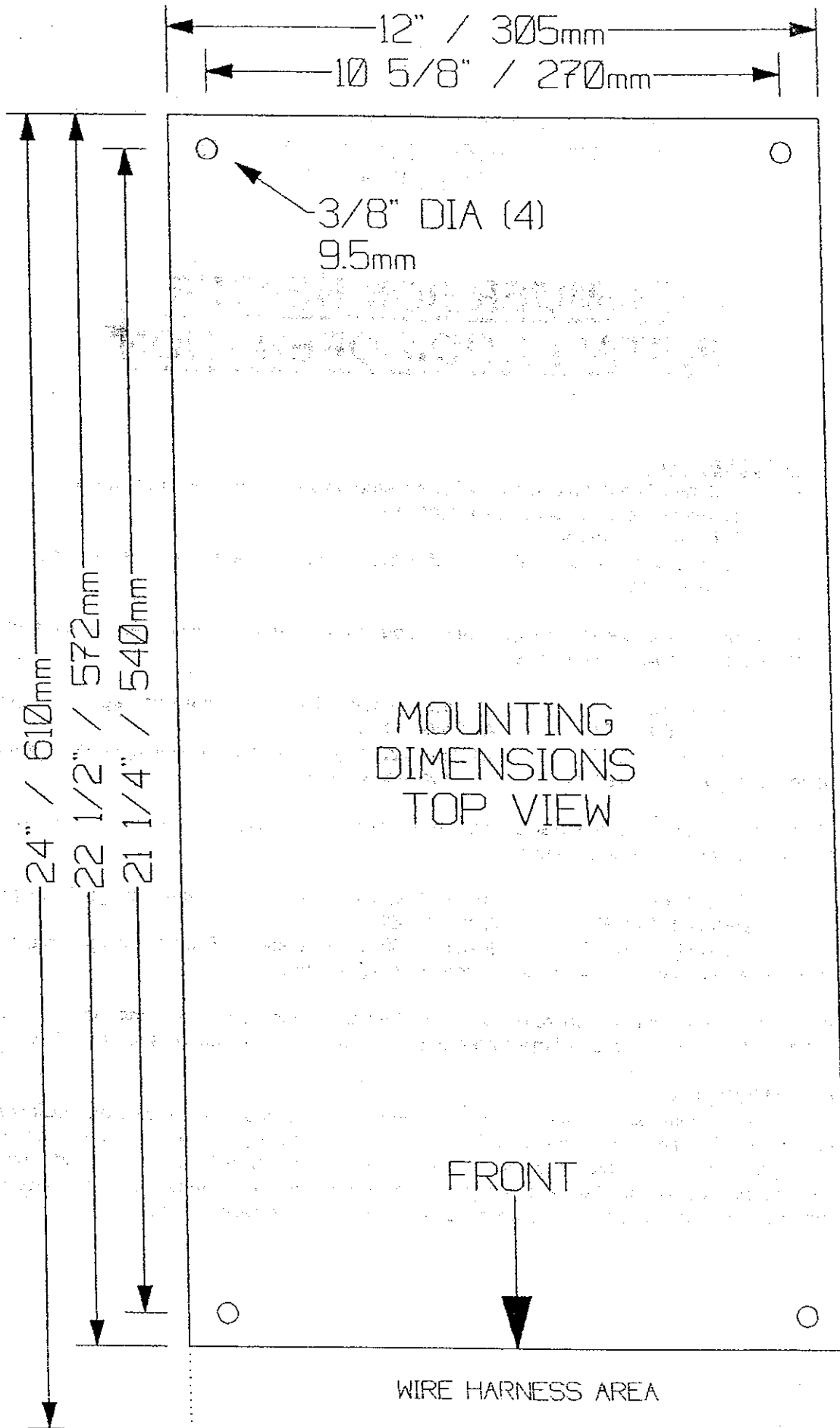

## OPERATION

The IH series heater module is controlled through the AQCWPH series remote panel. The only time that the heater module will operate is when the system is placed in the HEAT mode. Then, the number of heater stages that will be energized will depend upon the number of chiller switches ( located at the bottom of the AQCWPH panel ) that are turned on.

To start and run the IH immersion heater follow these steps:

1. Put the SYSTEM switch (top left switch) on the AQCWPH panel into the ON position. The amber ON indicator will then light and the main chillwater pump will start.
2. Put the HEAT-COOL switch (top right switch) into the HEAT position. On systems utilizing a single chiller, AQCWPH-01C remote panel and single stage IH heater module the system will now be operating. If this is not the case, continue to the next step.
3. Put the number of CHILLER UNIT switches into the ON position based on the number of heater stages that you want on. As the switch is turned on the heater contactor will pull in and energize that particular stage. At no time during the operation of the heating stage(s) will the chiller compressors be energized. The only components that will run will be the main chillwater pump and IH immersion heater.

The IH heater module will now begin to heat the water. The unit is equipped with a solid-state thermostat that will regulate the water temperature. The different stages will shut off as follows:

STAGE 1: 110° F  
STAGE 2: 105° F ( if so equipped )  
STAGE 3: 100° F ( if so equipped )

There is a 4° F differential between when the stage goes on and off.

## **IH IMMERSION HEATER SPARE PARTS**

### HEATER ELEMENTS

210530-10	1.0 KW 240-1
210530-15	1.5 KW 240-1
210530-20	2.0 KW 240-1
210530-25	2.5 KW 240-1
210530-30	3.0 KW 240-1
210530-35	3.5 KW 240-1
210530-45	4.5 KW 240-1

### RELAYS / CONTACTORS

205101-01	3 POLE 35A (RESISTIVE) CONTACTOR
205104-00	2 POLE 30A (RESISTIVE) CONTACTOR
205107-00	2 POLE 50A (RESISTIVE) CONTACTOR
217009-01	3PDT CHANGEOVER RELAY

### THERMOSTATS

222118-01	1 STAGE CONTROLLER
222118-19	2 STAGE CONTROLLER
222118-27	3 STAGE CONTROLLER
222118-15	SENSOR FOR 222118 SERIES CONTROLLERS

### WIRE EXTENSIONS

PPE-05	5' MAIN POWER CABLE EXTENSION
PPE-10	10' MAIN POWER CABLE EXTENSION
PPE-15	15' MAIN POWER CABLE EXTENSION
PPE2-05	5' SENSOR WIRE EXTENSION
PPE2-10	10' SENSOR WIRE EXTENSION
PPE2-15	15' SENSOR WIRE EXTENSION

CHR	CHANGEOVER RELAY
HC	HEATING CONTACTOR
HE	HEATING ELEMENT
HT	HEATING THERMOSTAT
TB	TERMINAL BLOCK POSITION

# CONTROL CIRCUIT SCHEMATICS

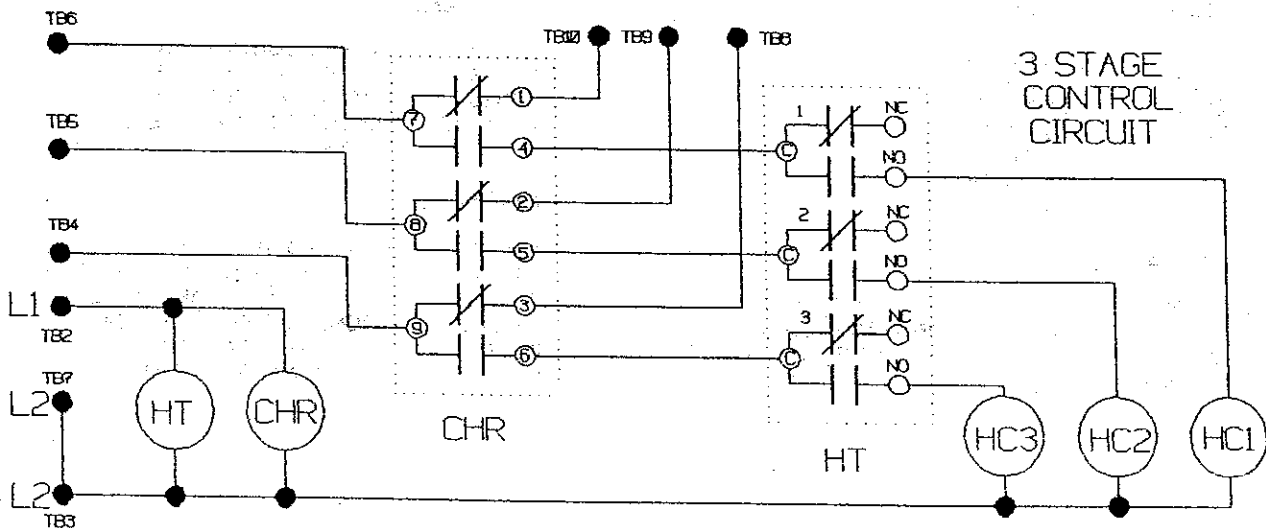
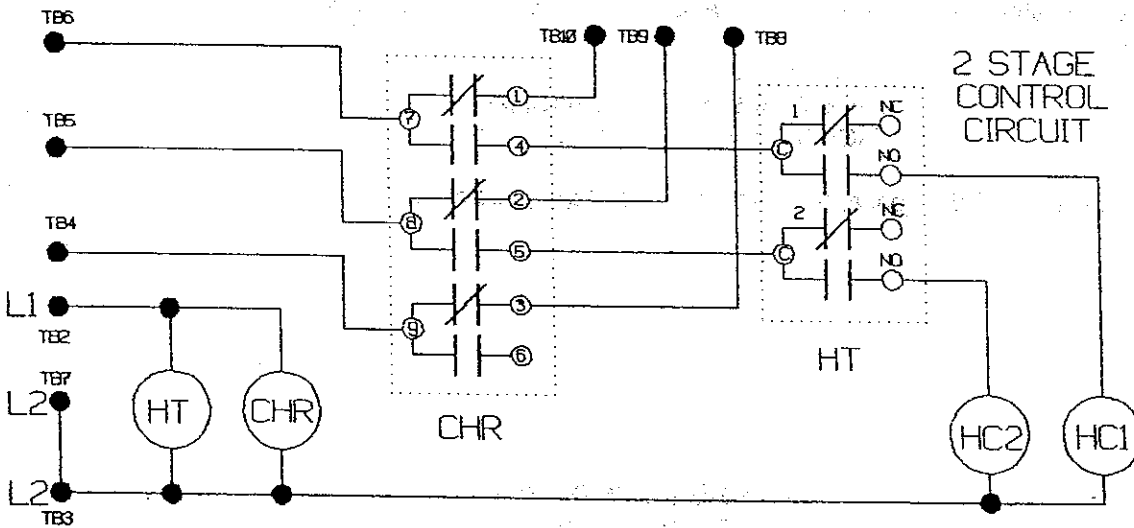
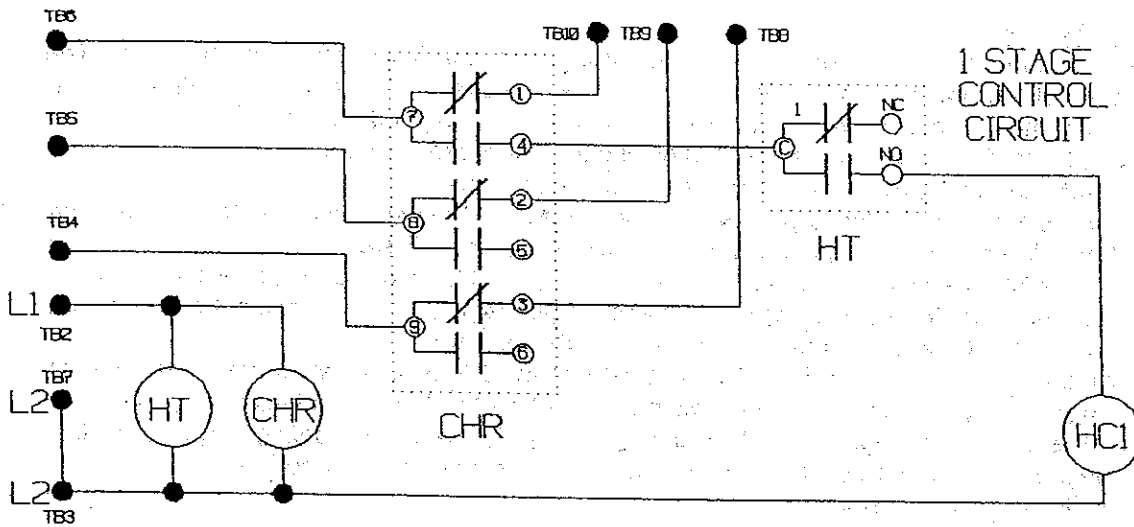

Along with the normal upright mounting position there are several alternatives that are available. These alternatives are shown in the accompanying drawings. There are no other positions that the heater module can be mounted in and still be self-purging of air.

**CAUTION: The heater module tank MUST BE FULL OF WATER before operating. The heating elements WILL BE DAMAGED if energized for even a short period of time while the tank is dry, thus voiding the warranty.**

If mounted independently the heater module should be bolted down on all four corners with 3/8" bolts. It is not necessary to vibration mount the heater module as there are no vibration producing items on the IH module. The electrical box can then be left attached to the top of the heater module or remotely mounted on a wall. If remotely mounted, optional plug-in extension wires are available to connect the electrical box to the heater module.

The module can also be bolted directly under any of the Alpha series 2-5 ton chillers. The mounting holes in the bottom of the chiller match up with the four mounting holes in the top of the heater module.

### ALTERNATE HEATER MODULE MOUNTING POSITIONS

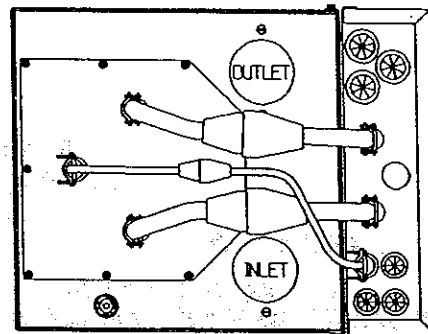
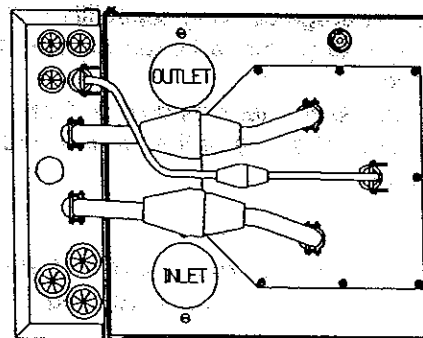
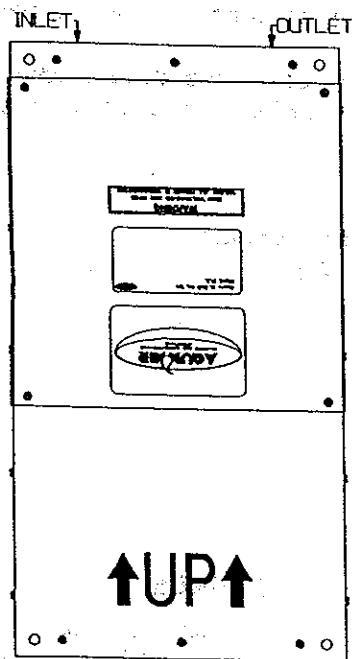

### HEATER MODULE PIPING

All piping that is connected to the IH heater module must be suitable for use with hot water systems. Examples of this are type 'M' copper, CPVC and single braid heater hose.

A ball or gate valve should be installed on both sides of the heater tank to allow you to isolate the heater tank and pressure relief valve from the rest of the system in case of an element or pressure relief valve failure. The connections from the system piping circuit to the heater tank should be easily removable ( i.e. union ) to allow for removal of the heater module. Any hose connections to the heater module must be made with a minimum of single braid heater hose, double clamped on both ends of the hose.

A pressure relief valve, model number IHPRV-75 must be piped in between the heater module and the isolation valves.

The water connections on the front of the heater module are both 2" FPT. These can be reduced down to the pipe size you are using with either brass or CPVC fittings.

### WIRING

There are two classifications of wiring necessary to connect the IH series heater module and electrical box: control circuits and main power feeds for each heater stage.

The control circuits are all of the wires that connect the AQCWPH series remote panel ( which also controls the chillers and main chillwater pump ) to the IH heater module electric box and the wires that connect the Alpha chiller(s) to the IH heater module electric box. All of this can be done in 16ga or larger wire. All control circuitry is 240 volt.

Wiring for the main power feeds must be sized according to the amperage draw of each heater stage. An example of this is the IH-2401-122 heater module. The total amperage draw of the unit is 51 amps at 240-1. Because there are two stages this amperage figure is split in half ( 25.5 amps ) for each stage. Therefore it would be necessary to use 10ga wire for each stage. This wire would be connected to the heater contactor inside the electrical box. It then would be connected to an appropriately sized circuit breaker on the ship's panel. In this case the circuit breaker would be a 30 amp.

Always remember that the circuit breaker must adequately protect not only the heater elements but also the wire connecting the two. A breaker must not be larger in amperage rating than the amperage carrying capability of the wire. An example of this is you would not use a 30 amp breaker to protect a heater utilizing 12ga wire ( usually good for 20 amps ) as the main power feed.

Both the heater tank module and the electric box must be grounded to the ship's electrical panel ground. The size of the ground wire must be equal to the size of the wire used for each heater stage.

***Failure to ground both the electrical box and heater module as described can result in injury or death !***

## IH IMMERSION HEATER ELECTRICAL SPECIFICATIONS

### 240-1PH UNITS

### 240-3PH UNITS

MODEL	TOTAL		WIRE SIZE EA. STAGE	CIRCUIT BREAKER SIZE PER STAGE	MODEL	TOTAL		WIRE SIZE EA. STAGE	CIRCUIT BREAKER SIZE PER STAGE
	AMPS	STAGES				AMPS	STAGES		
IH-2401-061	26	1	10	30	IH-2403-061	15	1	12	20
IH-2401-091	38	1	6	40	IH-2403-091	22	1	10	25
IH-2401-092	38	2	10	25					
IH-2401-122	51	2	10	30	IH-2403-122	29	2	12	20
IH-2401-123	51	3	12	20					
IH-2401-152	64	2	8	40	IH-2403-152	36	2	12	20
IH-2401-153	64	3	10	25					
IH-2401-182	76	2	6	40	IH-2403-182	44	2	10	25
IH-2401-183	76	3	10	30					
IH-2401-212	89	2	6	50	IH-2403-212	52	2	10	30
IH-2401-213	89	3	8	30					
IH-2401-243	100	3	8	40	IH-2403-242	58	2	10	30
IH-2401-273	114	3	6	40	IH-2403-272	65	2	8	40

- |     |                      |     |                      |
|-----|----------------------|-----|----------------------|
| CC  | COMPRESSOR CONTACTOR | HC  | HEATING CONTACTOR    |
| CCR | COMPRESSOR RELAY     | HCS | HEAT-COOL MODE SW.   |
| CL  | COOLING LIGHT        | HPS | HIGH PRESSURE SWITCH |
| CLL | COOLING LIGHT        | HT  | HEATING THERMOSTAT   |
| CSW | COMPRESSOR SWITCH    | LPS | LOW PRESSURE SWITCH  |
| DT  | DIGITAL THERMOSTAT   | PN  | POWER ON LIGHT       |
| FH  | FUSE HOLDER          | SSM | SYSTEM SWITCH        |
| FU  | FUSE                 | TB  | TERMINAL BLOCK       |
| FZT | FREEZEUP THERMOSTAT  | TD  | TIME DELAY           |

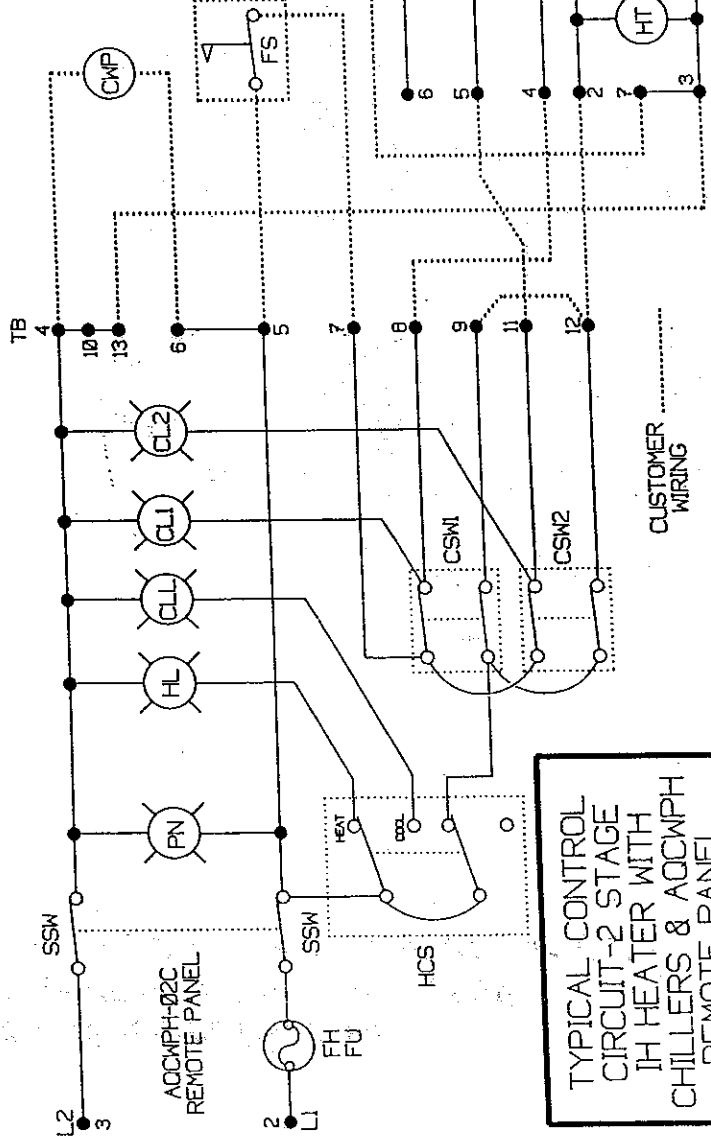
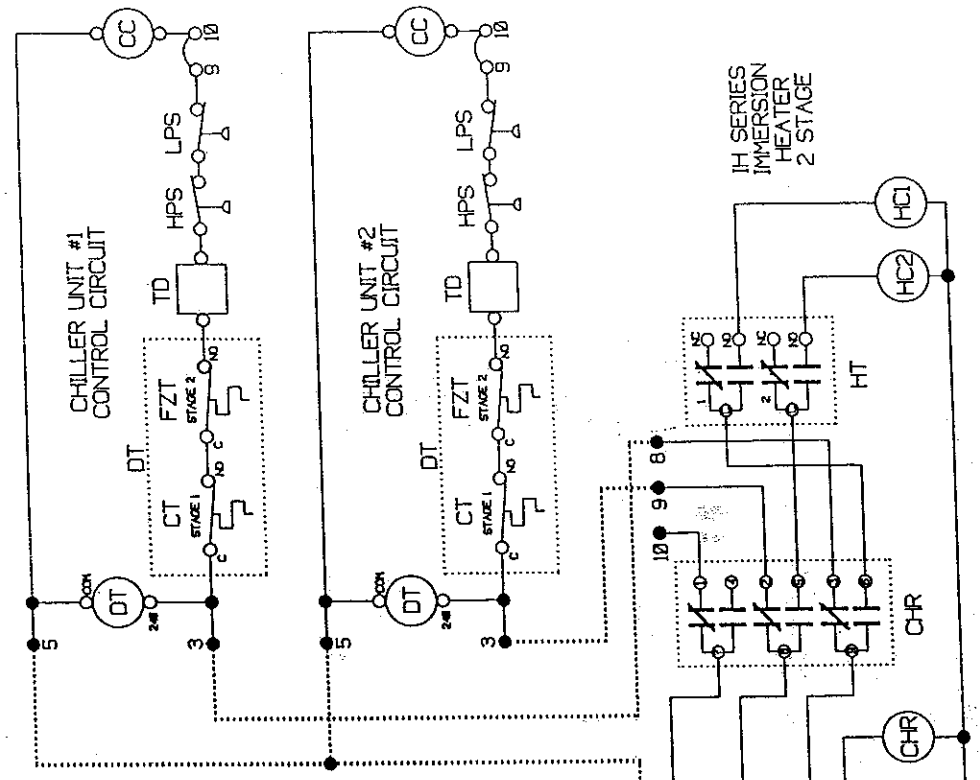

TYPICAL CONTROL CIRCUIT-2 STAGE IH HEATER WITH CHILLERS & ACCMPH REMOTE PANEL

CUSTOMER WIRING

# ELECTRICAL BOX COMPONENT IDENTIFICATION

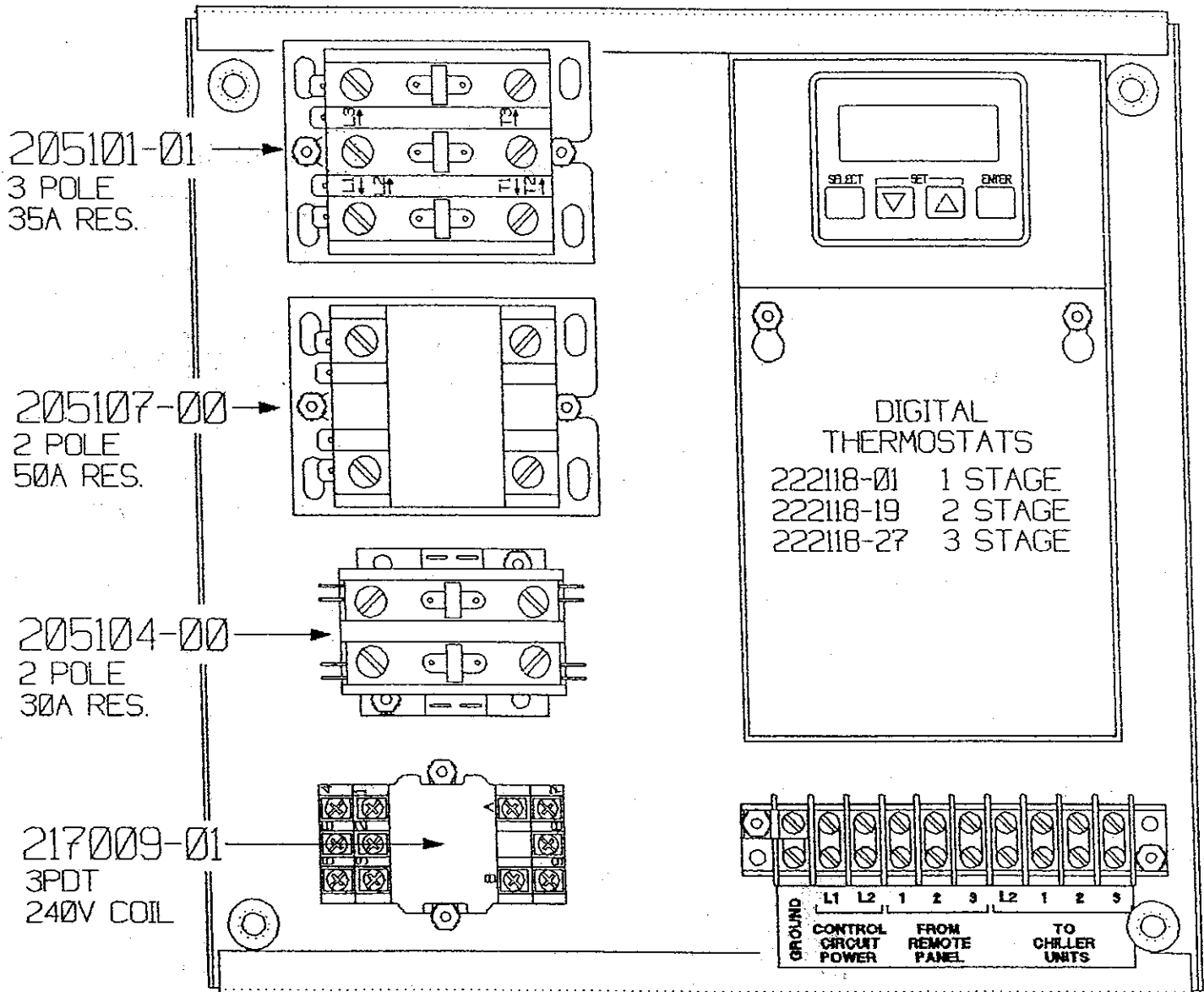

**AQUA-AIR MANUFACTURING, div. of the James D. Nall Co., Inc.**  
**1050 E. 9th Street Hialeah, Florida 33010 U.S.A.**  
**PH. 305-884-8363 FAX 305-883-8549**