

## **FEATURES**

- ' Two models to choose from ranging in size from 250 to 500 CFM
- ' Rotatable blower for installation in virtually any location
- ' Unit can be operated in the fan only mode or the heating mode
- ' 1050 RPM motors for quiet operation
- ' Remote panel for control of operating mode and fan speed
- ' Round duct collar for ease in connecting to flex duct
- ' Rubber mounting feet to prevent vibration from transferring to the deck

<b>SPECIFICATIONS</b>	<b>DF-250C</b>	<b>DF-500C</b>
<b>HEATING CAPACITY</b>	3,415 BTU/H 861 KCAL/H	6,830 BTU/H 1,721 KCAL/H
<b>AIR FLOW CAPACITY</b>	250 CFM 425 M <sup>3</sup> H	500 CFM 850 M <sup>3</sup> H
<b>WEIGHT</b>	23 POUNDS 10.5 KGS	27 POUNDS 12.3 KGS
<b>CURRENT DRAW , AMPS @ 230-1-60</b>	5.3	10.2
<b>POWER CONSUMPTION</b>	1,127	2,460
<b>MINIMUM RETURN AIR</b>	64 IN <sup>2</sup> 413 CM <sup>2</sup>	144 IN <sup>2</sup> 929 CM <sup>2</sup>
<b>MINIMUM SUPPLY AIR</b>	25 IN <sup>2</sup> 161 CM <sup>2</sup>	72 IN <sup>2</sup> 464 CM <sup>2</sup>
<b>FLEX DUCT COLLAR</b>	4" 100mm	6" 150mm
<b>STANDARD HEATER SIZE, kW</b>	1.0	2.0

I:\wordpfct\80950.wpd

**AQUA-AIR MANUFACTURING, division of the James D. Nall Co., Inc.**  
**1050 East 9th Street, Hialeah, Florida 33010 U.S.A.**  
**Ph. 305-884-8363 Fax 305-883-8549**

4" FLEX DUCT  
CONNECTOR  
AIR OUTLET

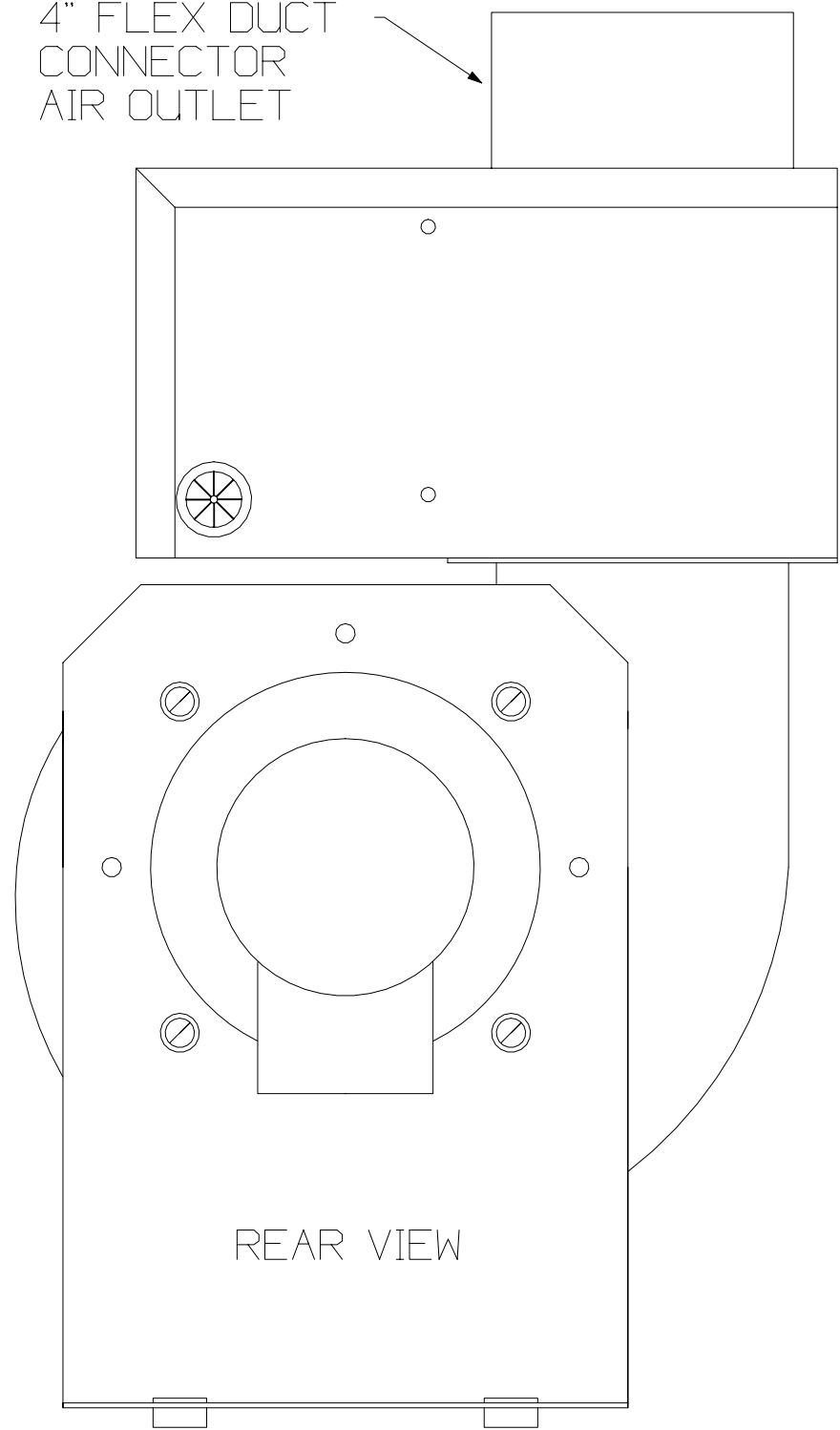

10-5/8"

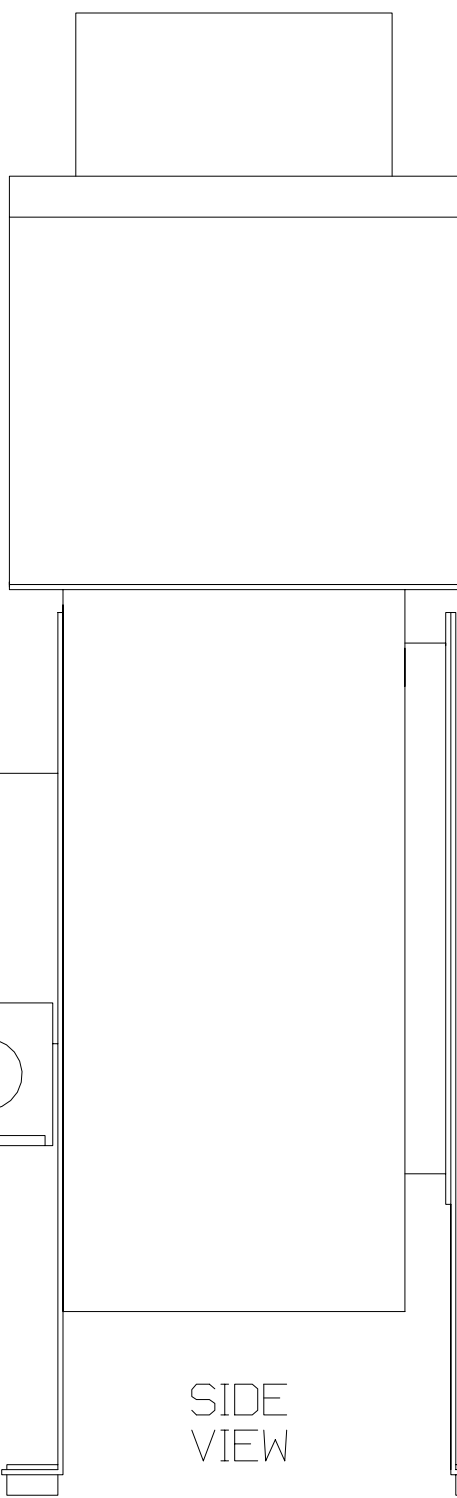

8-7/8"

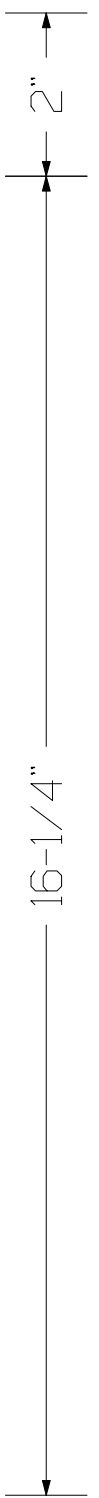

CONTROL CIRCUIT  
FUSE  
WIRING ACCESS

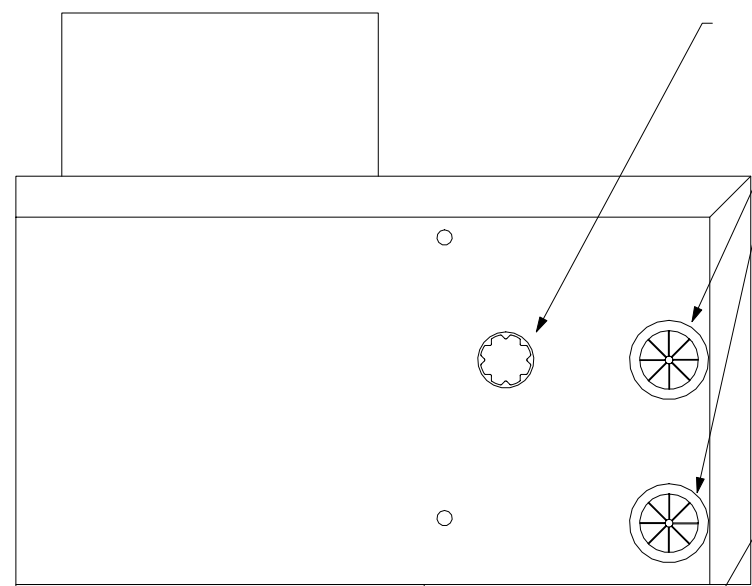

AIR INLET

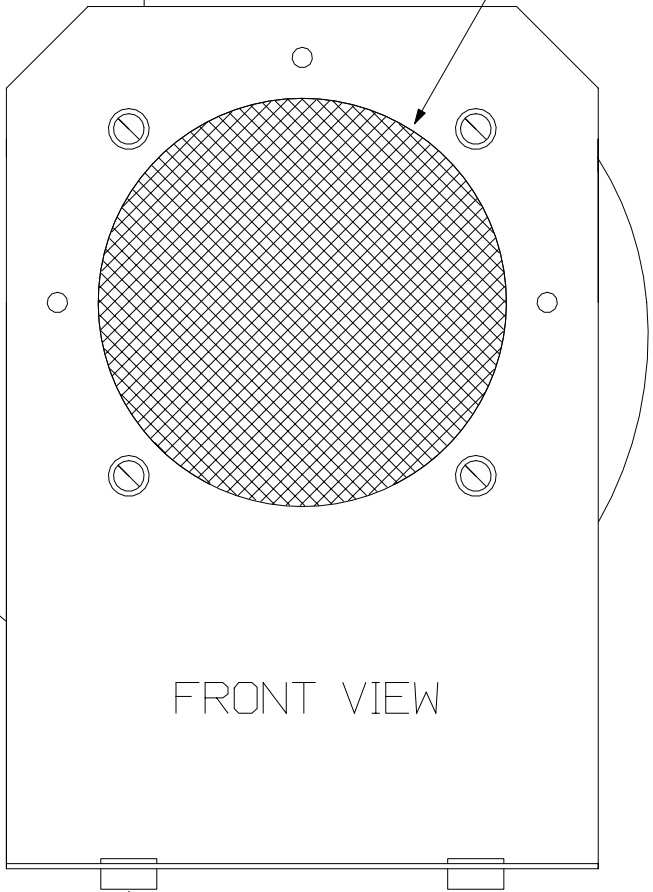

VIBRATION MOUNTS (4)

BLOWER IS ROTATABLE

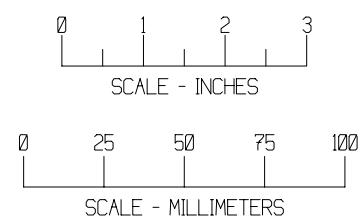

<b>AQUA-AIR</b> MARINE AIR CONDITIONING SYSTEMS			
DF-250 DEFOGGER UNIT			
DRAWING NUMBER	DF-250	DRAWN BY	DN
		DATE	1-95
APPROVED BY		REVISION DATE	REV A

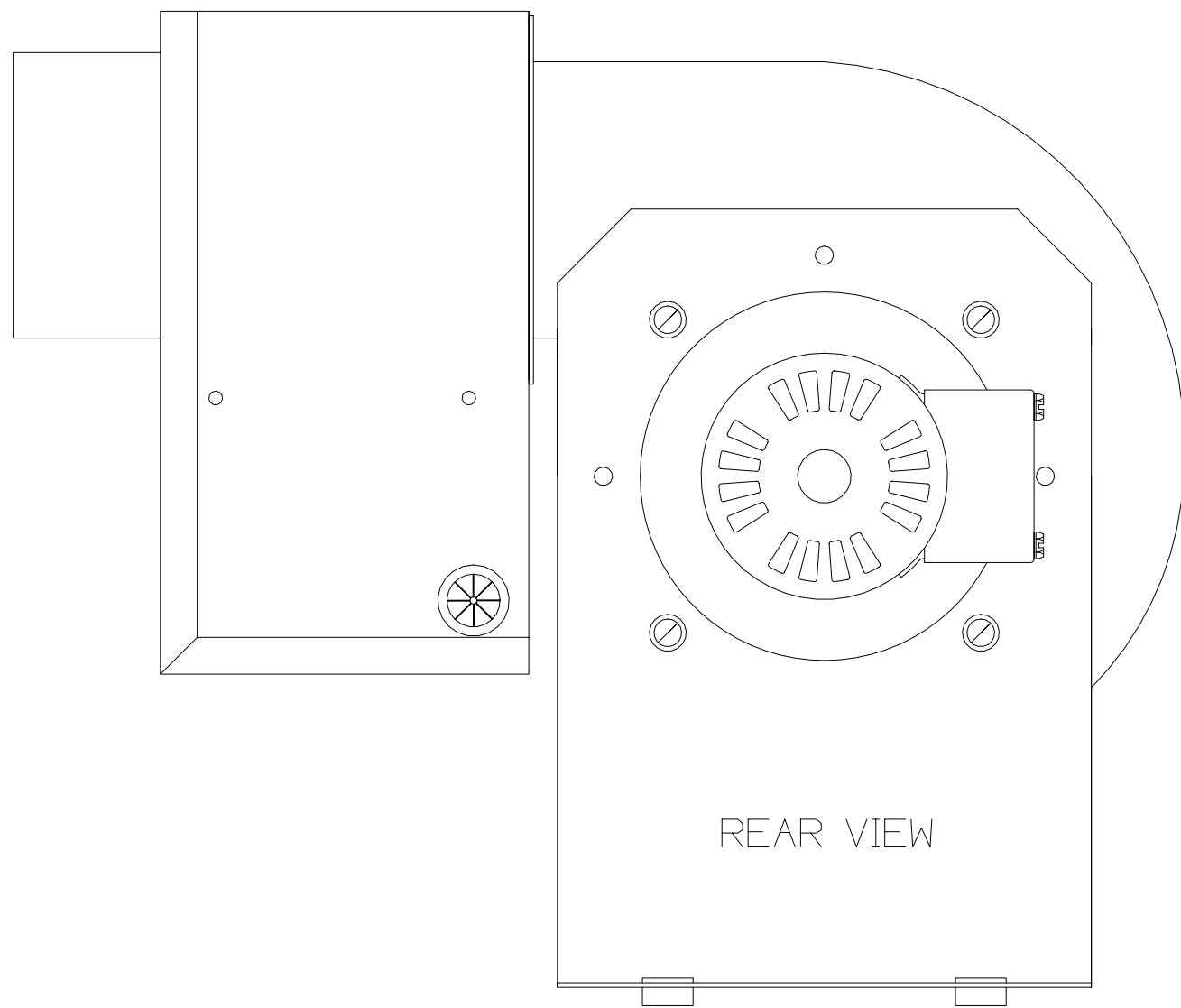

REAR VIEW

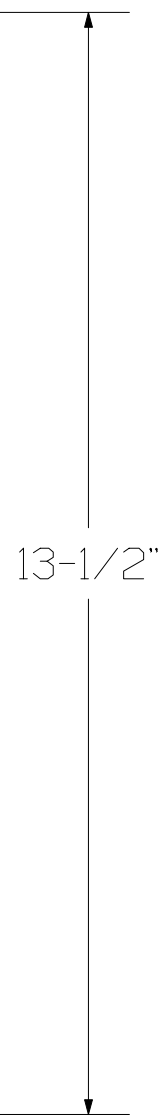

13-1/2"

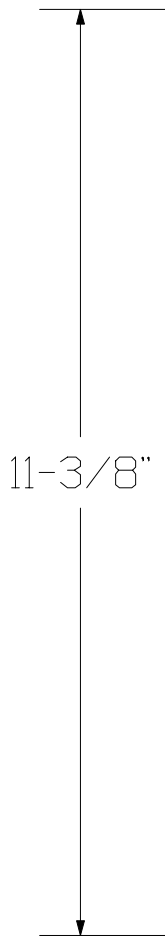

11-3/8"

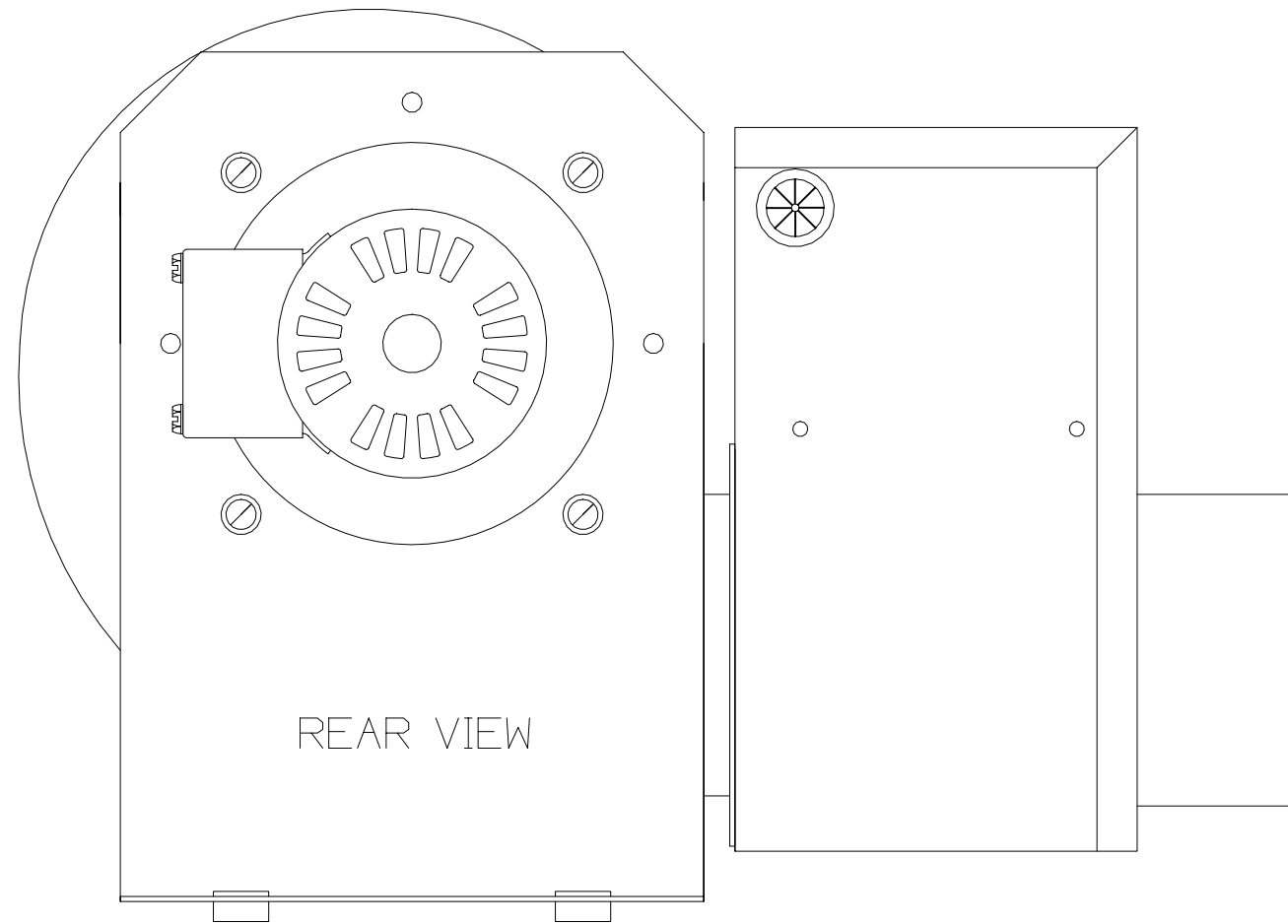

REAR VIEW



14"

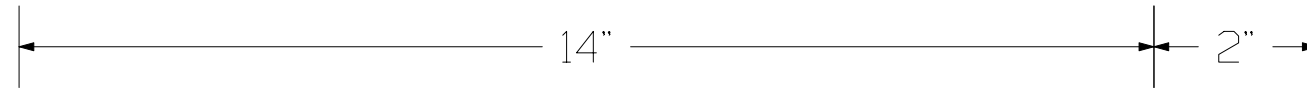

14"

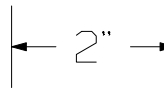

2"

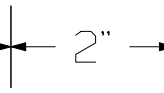

2"

BLOWER IS ROTATABLE

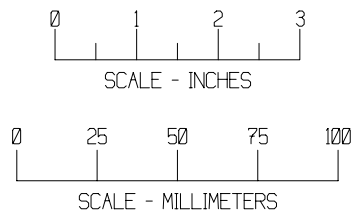

<b>AQUA-AIR</b>		MARINE AIR CONDITIONING SYSTEMS	
DF-250 DEFOGGER UNIT ROTATION OPTIONS			
DRAWING NUMBER	DF-250	DRAWN BY	DN
		DATE	1-95
APPROVED BY		REVISION DATE	
			REV A

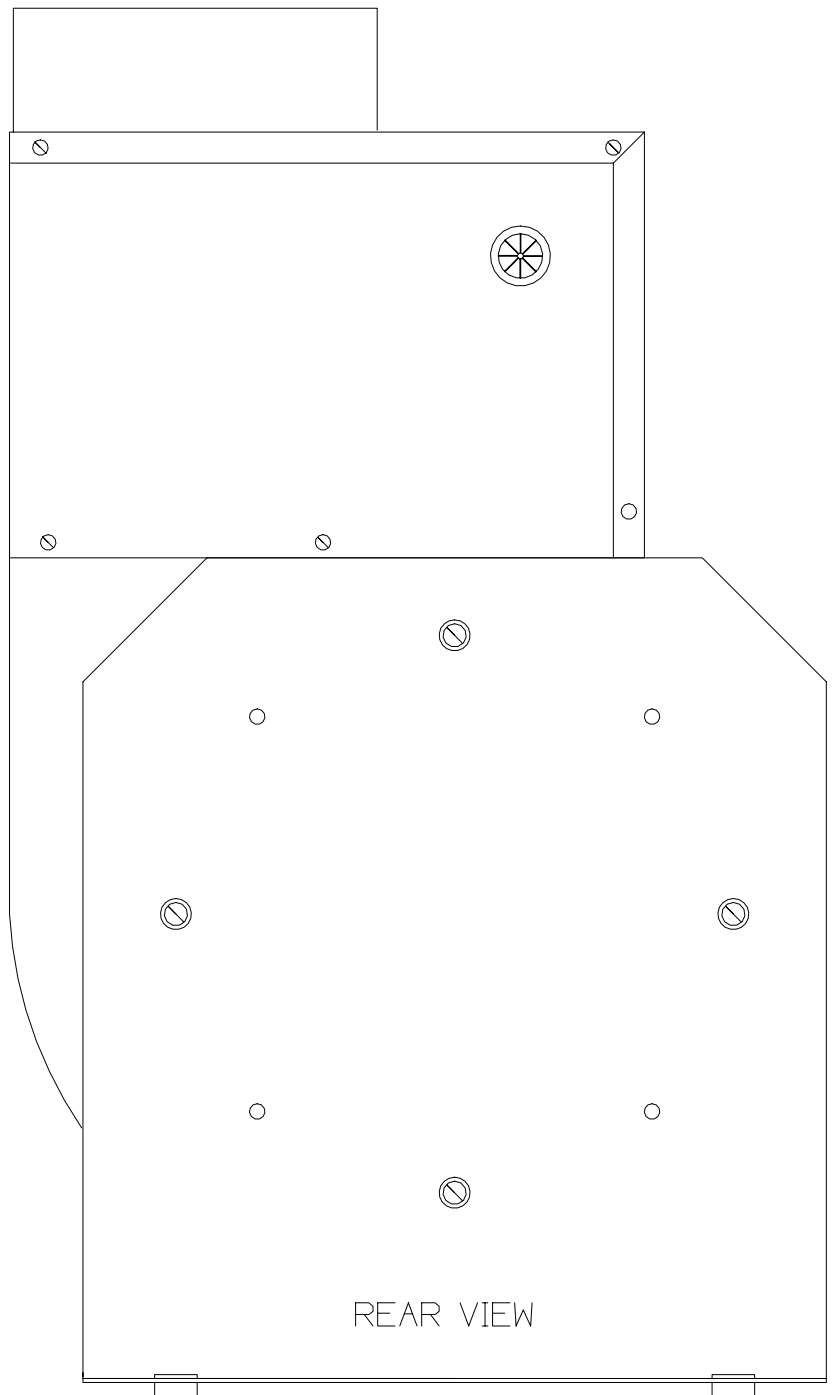

REAR VIEW

2"  
20-1/2"

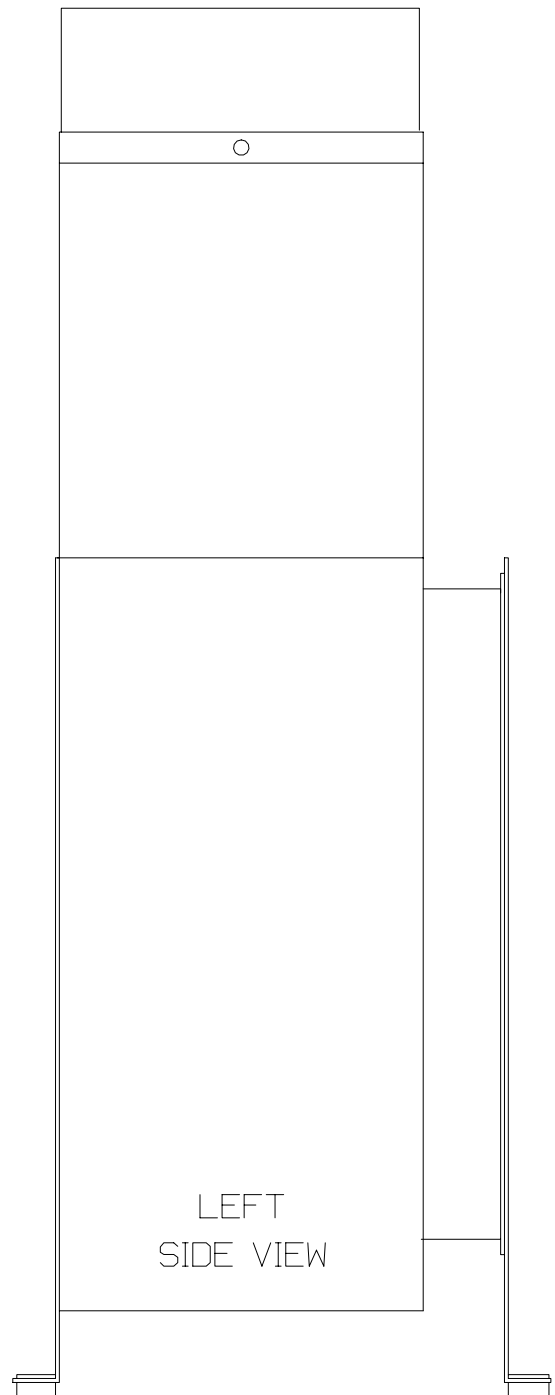

LEFT SIDE VIEW

8-3/4"

BLOWER IS ROTATABLE

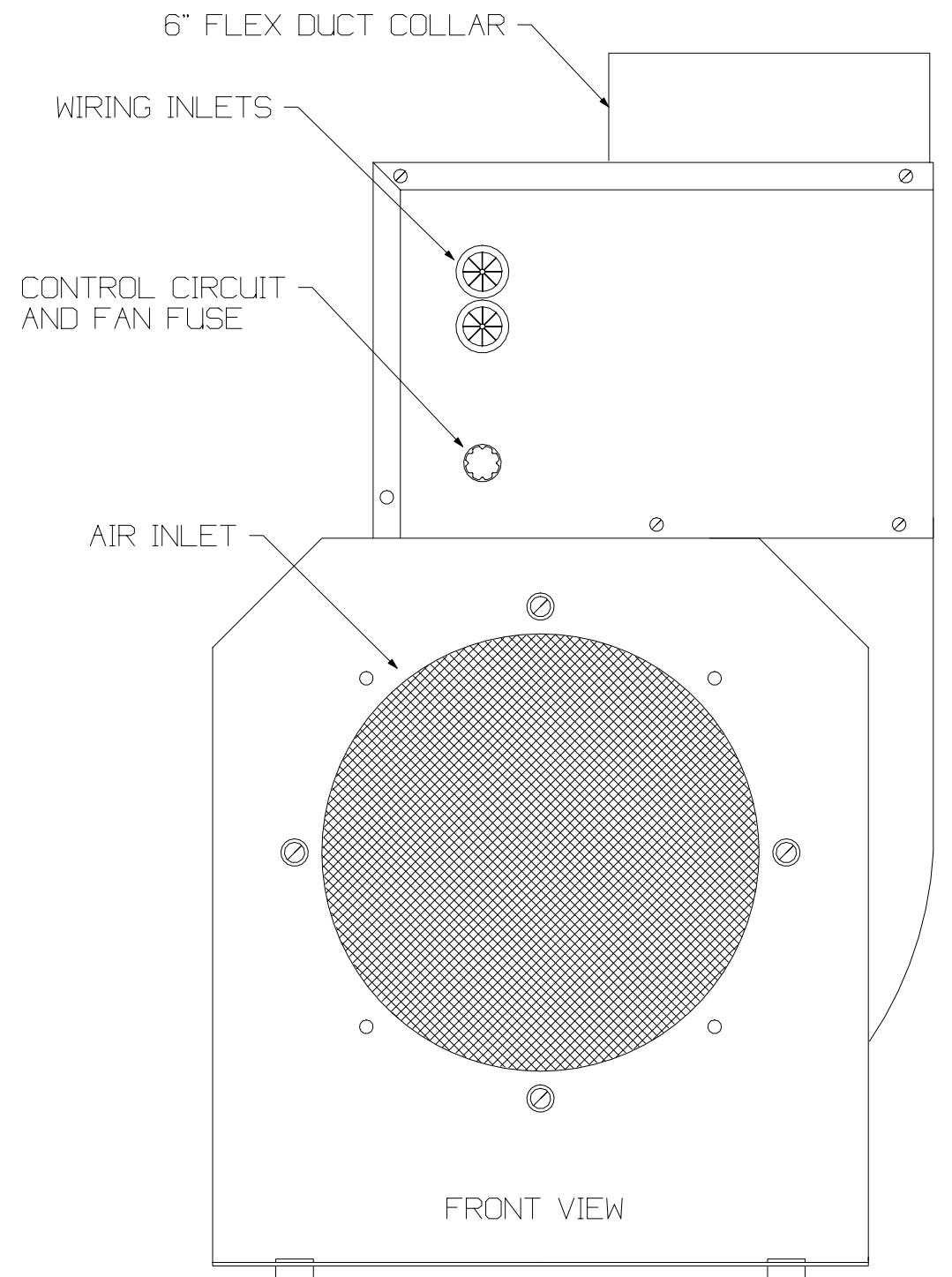

FRONT VIEW

13-1/4"

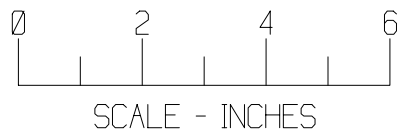

SCALE - INCHES

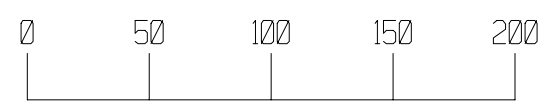

SCALE - MILLIMETERS

<b>AQUA-AIR</b> MARINE AIR CONDITIONING SYSTEMS			
DF-500 DEFOGGER UNIT			
DRAWING NUMBER	DF-500	DRAWN BY	DN
SCALE	NONE	DATE	1-95
APPROVED BY		REVISION DATE	
			REV A

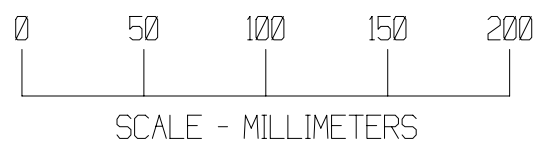
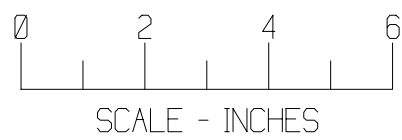
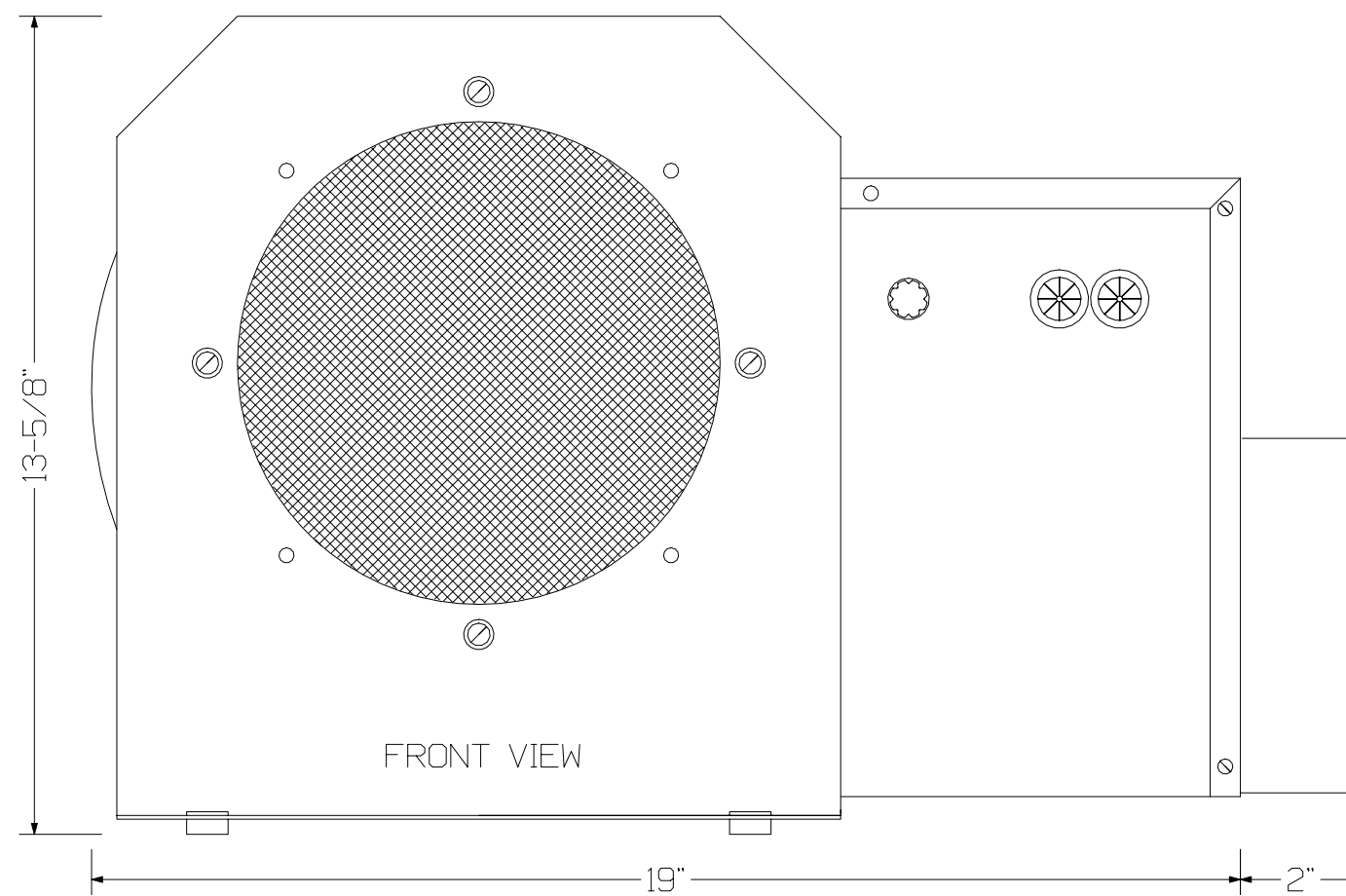
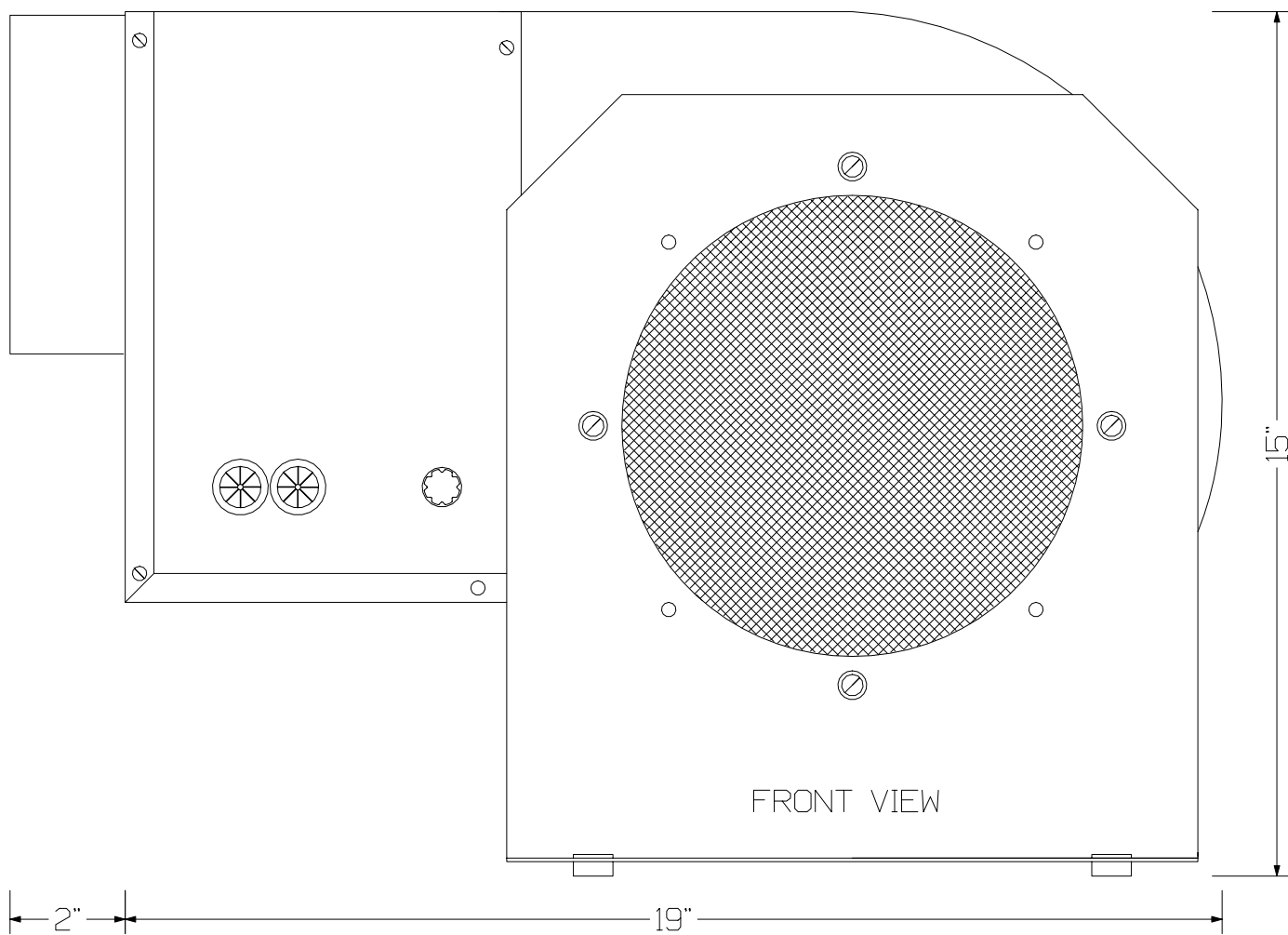

BLOWER IS  
ROTATABLE

**AQUA-AIR** MARINE AIR CONDITIONING  
SYSTEMS

DF-500 DEFOGGER UNIT  
ROTATION OPTIONS

DRAWING NUMBER	DF-500	DRAWN BY	DN	DATE	1-95
SCALE	NONE	APPROVED BY		REVISION DATE	
					REV A

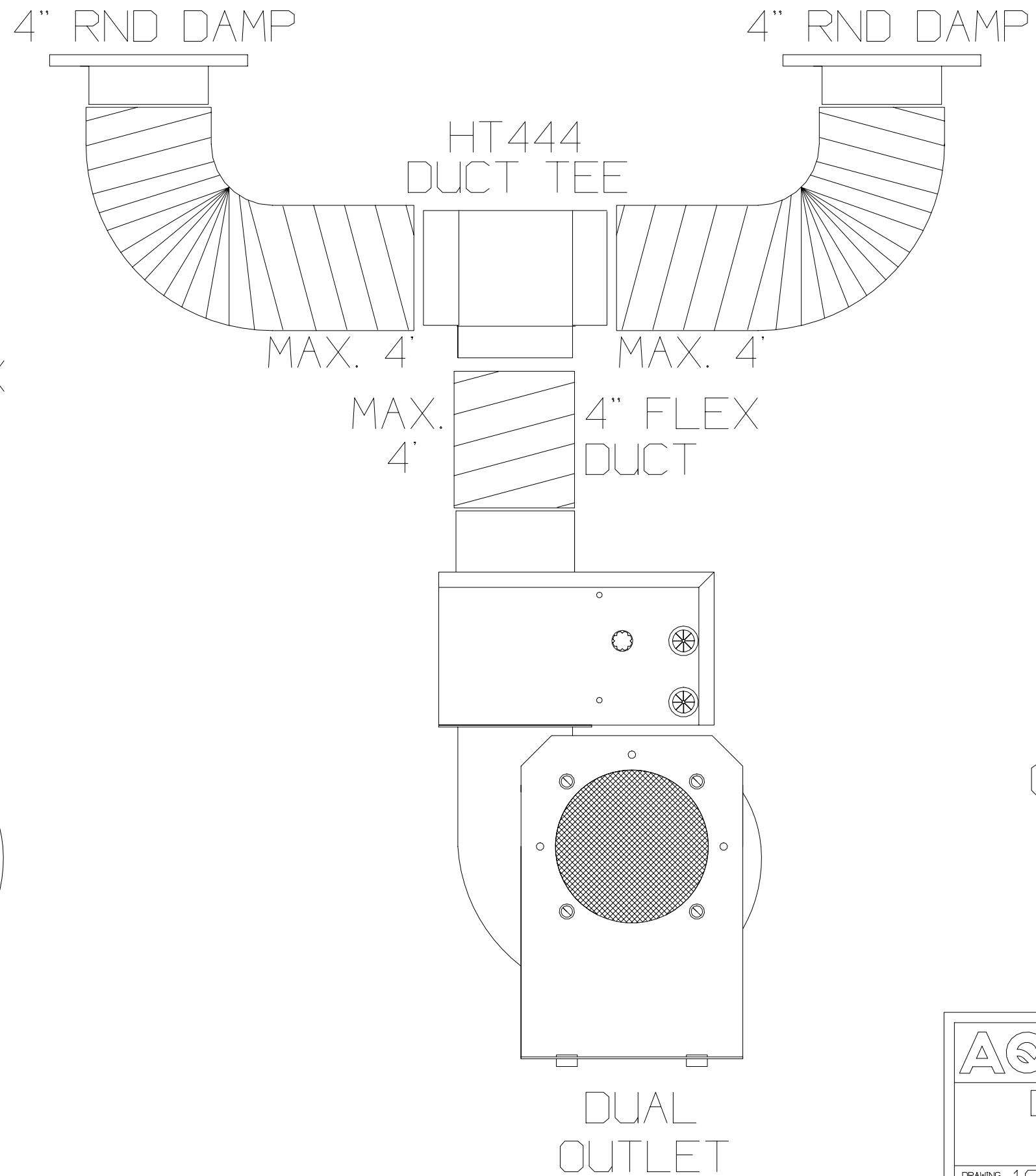
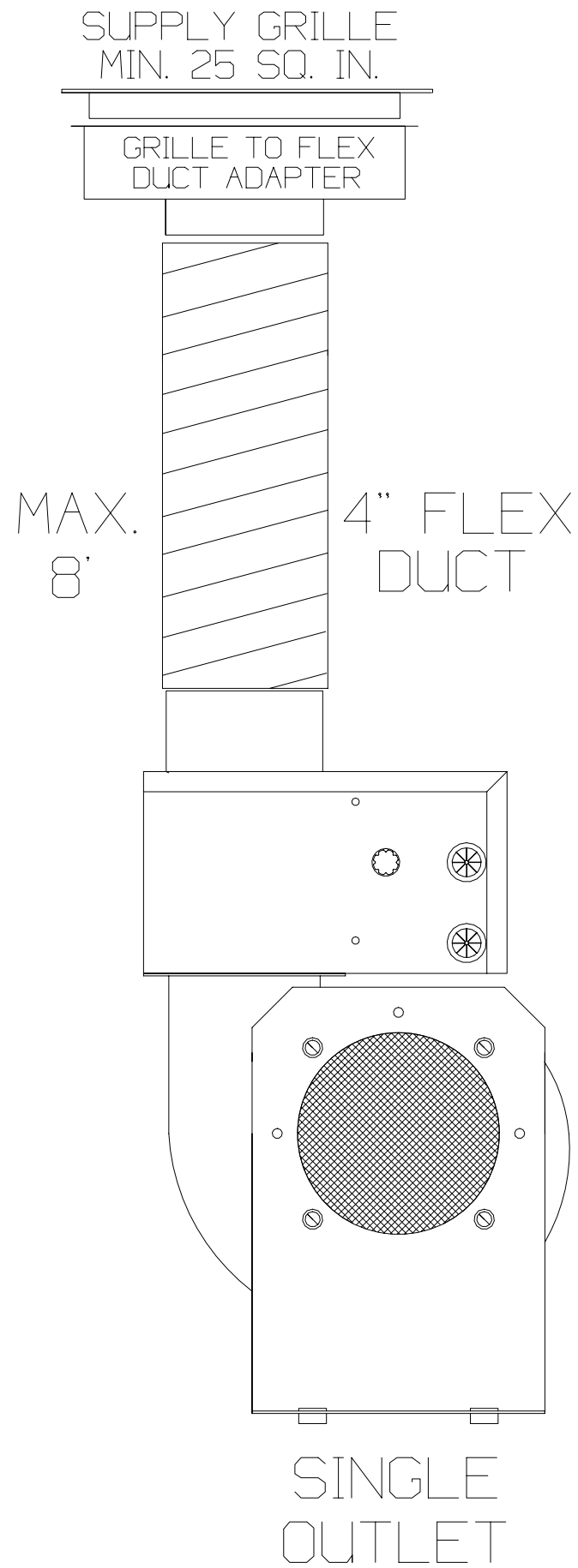

RETURN AIR  
GRILLE REQUIRED  
MIN. 64 SQ. IN.

<b>AQUA-AIR</b>		MARINE AIR CONDITIONING SYSTEMS	
DF-250 SERIES DEFOGGER UNIT APPLICATIONS			
DRAWING NUMBER	1012-16	DRAWN BY	DN DATE 10-14-91
SCALE	NONE	APPROVED BY	REVISION DATE
			REV A

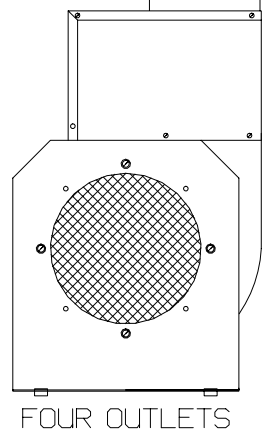
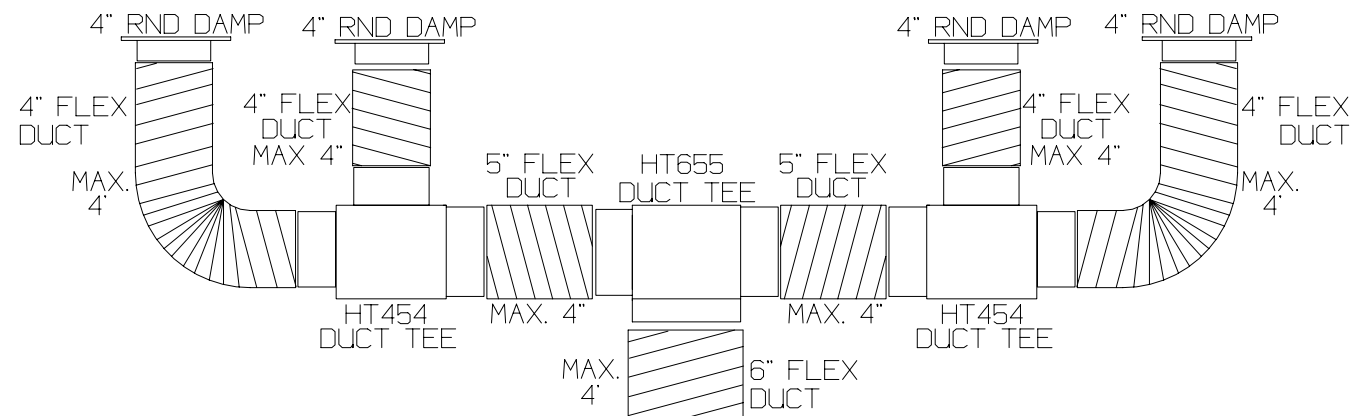

FOUR OUTLETS

MINIMUM RETURN AIR GRILLE AREA IS 144 SQ. IN.

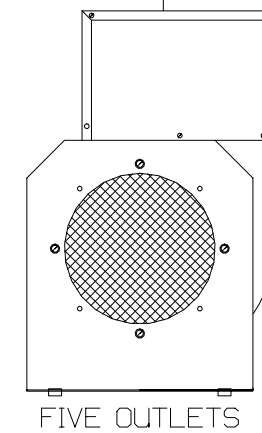
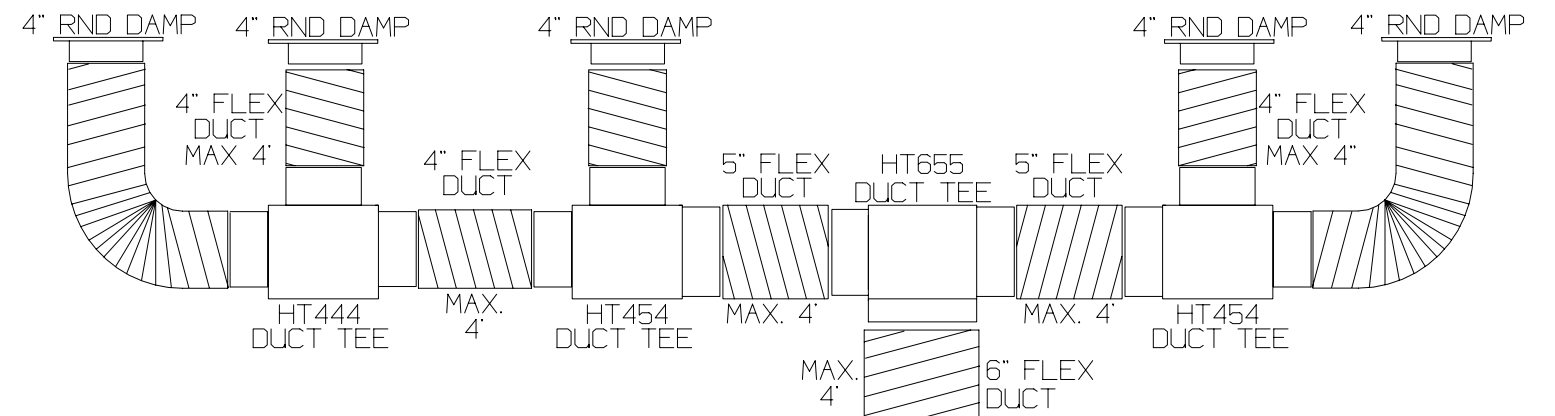

FIVE OUTLETS

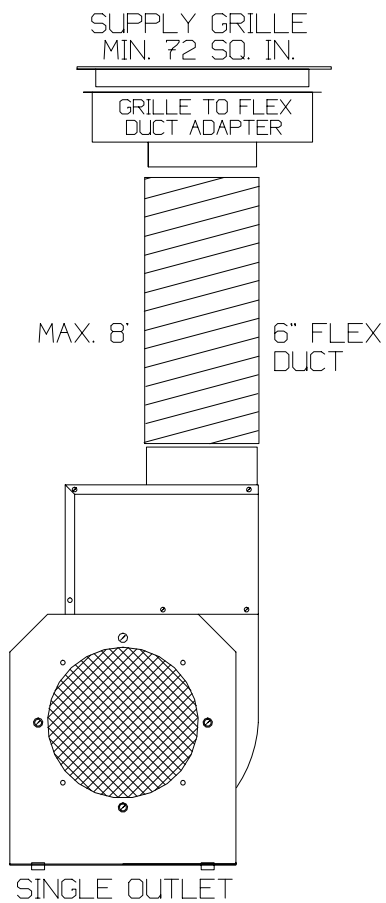

SINGLE OUTLET

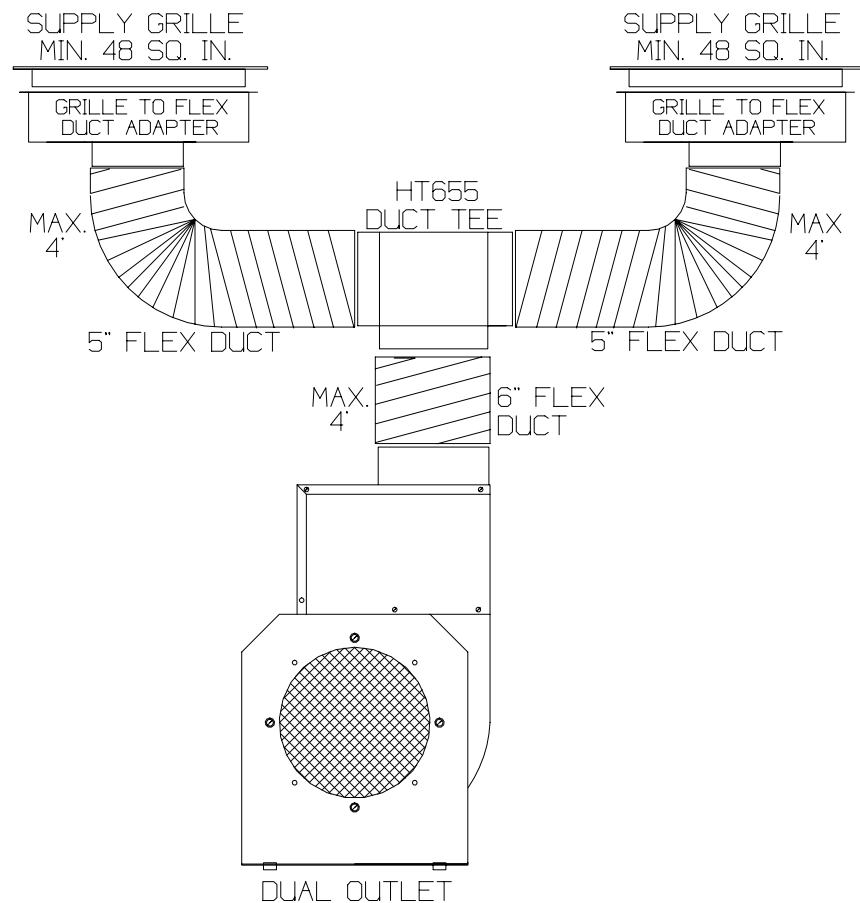

DUAL OUTLET

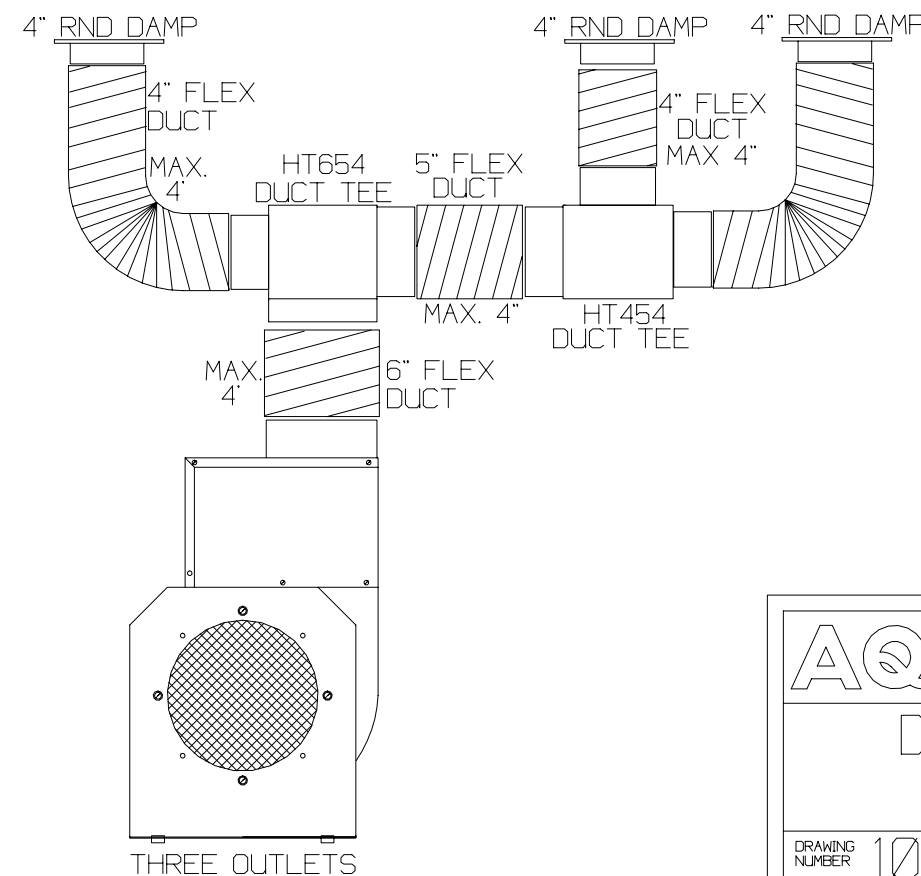

THREE OUTLETS

<b>AQUA-AIR</b> MARINE AIR CONDITIONING SYSTEMS			
DF-500 SERIES DEFOGGER UNIT APPLICATIONS			
DRAWING NUMBER	1012-17	DRAWN BY	DN
SCALE	NONE	DATE	10-15-91
APPROVED BY		REVISION DATE	
			REV B

# DF SERIES ELECTRICAL JUNCTION BOX



## DFSW CONTROL SWITCH

DFSW 115V  
DFSWC 230V

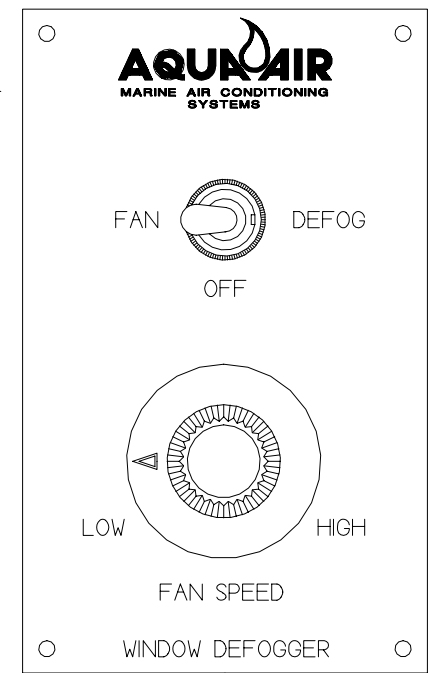

POWER INPUT

GROUND

L1

L2 or N

BLUE

ORANGE

BLACK

GREEN

16ga WIRE (4)

VOLTAGE      WIRE SIZE

DF250	115V	14ga
DF250C	230V	14ga
DF500	115V	10ga
DF500C	230V	14ga

**AQUA-AIR** MARINE AIR CONDITIONING SYSTEMS

DF SERIES DEFOGGER UNIT  
EXTERNAL WIRING TO DFSW(C) SWITCH  
115 or 230V

DRAWING NUMBER 4005-02A DRAWN BY DN DATE 10-14-91

SCALE NONE APPROVED BY REVISION DATE REV A